

KM55 Standard Type

A type : A single carriage-nut with standard length
 B type : Two carriage-nuts with standard length

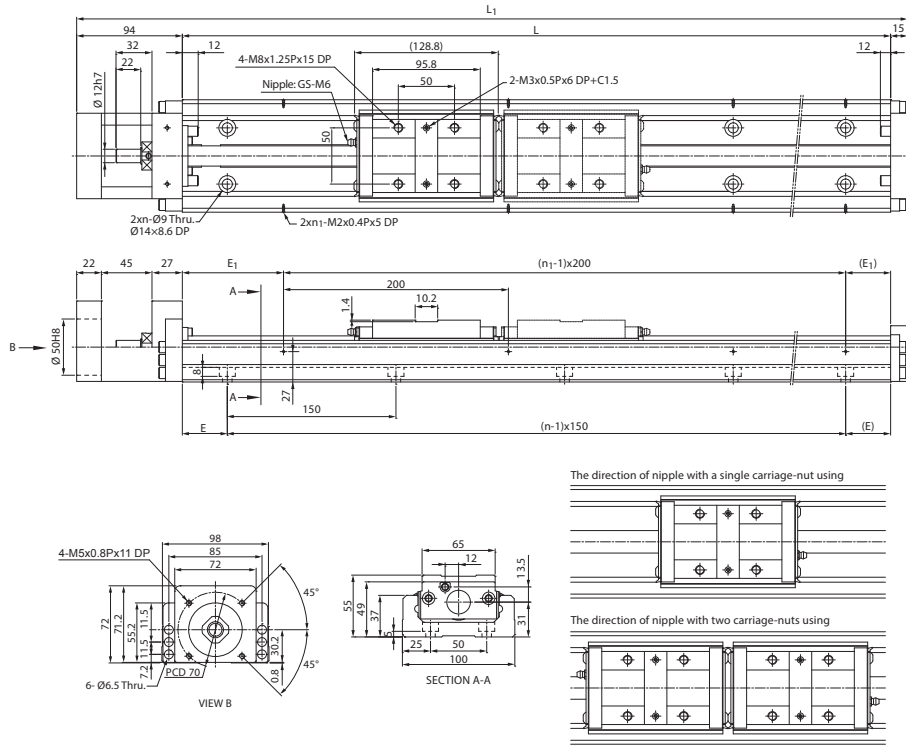

Unit : mm

| Rail Length L | Overall Length L ₁ | Max. Stroke | | E | n | E ₁ | n ₁ | Weight (kg) | |
|------------------|----------------------------------|-------------|--------|----|----|----------------|----------------|-------------|--------|
| | | A Type | B Type | | | | | A Type | B Type |
| 980 | 1089 | 800 | 680 | 40 | 7 | 90 | 5 | 19.90 | 21.62 |
| 1080 | 1189 | 900 | 780 | 15 | 8 | 40 | 6 | 21.63 | 23.35 |
| 1180 | 1289 | 1000 | 880 | 65 | 8 | 90 | 6 | 23.36 | 25.08 |
| 1280 | 1389 | 1100 | 980 | 40 | 9 | 40 | 7 | 25.09 | 26.81 |
| 1380 | 1489 | 1200 | 1080 | 15 | 10 | 90 | 7 | 26.82 | 28.54 |

Note*: The max. stroke of B type is base on two carriage-nuts used in closed contact with each other.

KM55 Cover Type

A type : A single carriage-nut with standard length
 B type : Two carriage-nuts with standard length

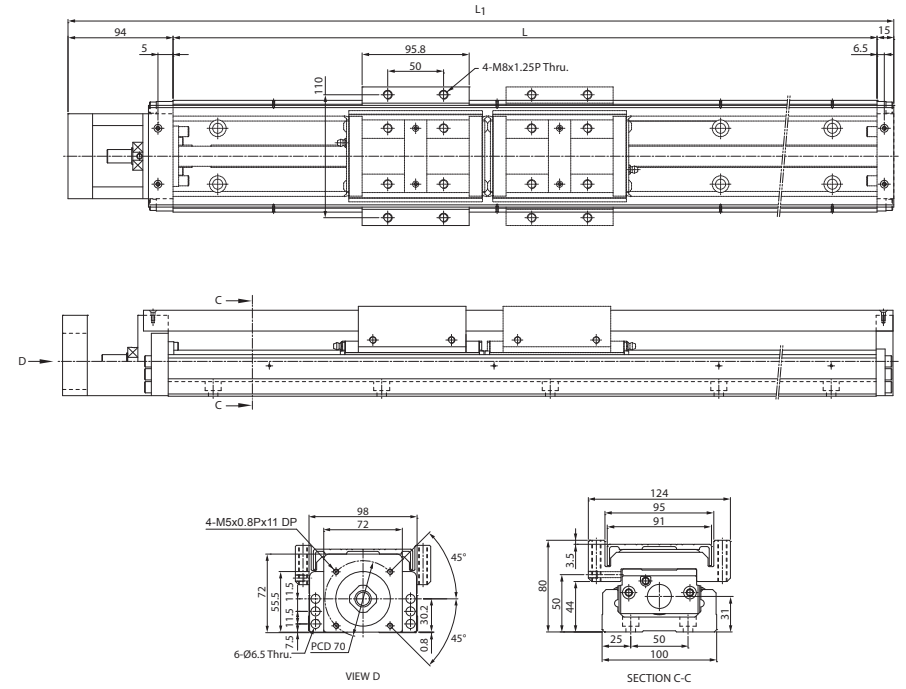

Unit : mm

| Rail Length L | Overall Length L ₁ | Max. Stroke | | Weight (kg) | |
|------------------|----------------------------------|-------------|--------|-------------|--------|
| | | A Type | B Type | A Type | B Type |
| 980 | 1089 | 800 | 680 | 21.78 | 24.25 |
| 1080 | 1189 | 900 | 780 | 23.61 | 26.08 |
| 1180 | 1289 | 1000 | 880 | 25.44 | 27.91 |
| 1280 | 1389 | 1100 | 980 | 27.26 | 29.73 |
| 1380 | 1489 | 1200 | 1080 | 29.09 | 31.56 |

Note*: The max. stroke of B type is base on two carriage-nuts used in closed contact with each other.